

f/I-f/f converter

2255



- Programmable f/I converter
- Programmable decimal divider / decimal multiplier
- Programmable frequency generator
- Relay output as option
- Supply voltage 24 VDC



Advanced features

- The user programmable version has a multifunction user interface consisting of three pushbuttons and a 3-digit LED displays.

Application

- Typical signalling devices may be pulse generators, for instance flow meters, tacho-generators or inductive sensors.
- The f/I function is used for frequency to current / voltage conversion.
- The f/f function is used for division or multiplication of pulses and as a buffer for fast pulse trains.
- A frequency generator function e.g. used as a time base or a clock generator.

Technical characteristics

- 3 front LEDs, indicating f.in active input (not NPN), Dig.out (NPN or relay 1) active output and a NAMUR input error signal.
- Analog current output can be configured within 0...20 mA range.
- Voltage output range is selectable between 0...10 VDC by use of internal jumpers.
- Feature include input filter, contact filter and an auxiliary supply for sensor such as NAMUR and S0.
- Mounting for a standard 11-pole socket which can be adapted for DIN rail or plate use with PR's 7023 adaptor and 7024 mounting keying.

Applications

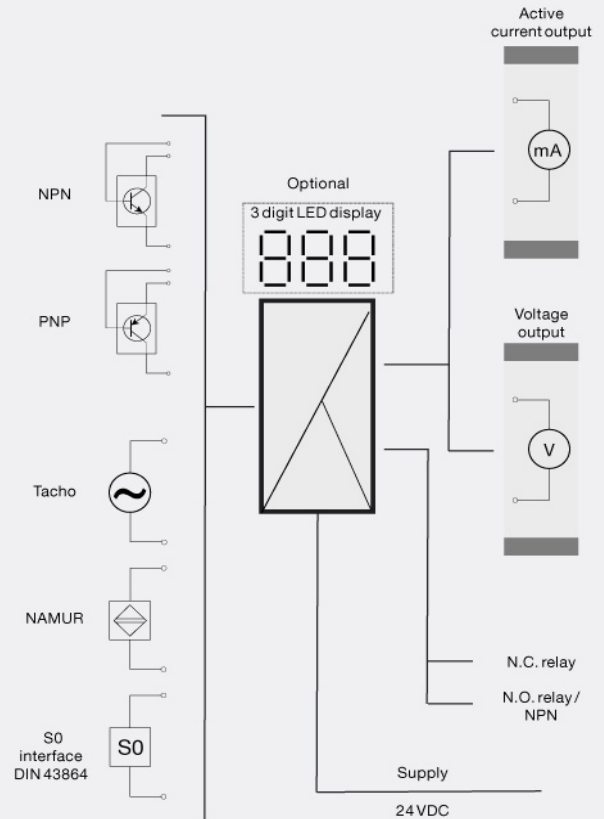

Order:

Type	Version	Output
2255	Programmable : B	Analog + NPN output : 1 Analog + relay output : 2

Environmental Conditions

Operating temperature.....	-20°C to +60°C
Calibration temperature.....	20...28°C
Relative humidity.....	< 95% RH (non-cond.)
Protection degree.....	IP50

Mechanical specifications

Dimensions (HxWxD).....	80.5 x 35.5 x 84.5 mm (D is without pins)
Weight approx.....	125 g

Common specifications

Supply

Supply voltage.....	19.2...28.8 VDC
Internal power dissipation.....	2.4 W

Isolation voltage

Isolation voltage, test / working.....	1.4 kVAC / 150 VAC
--	--------------------

Response time

Response time (programmable).....	60 ms to 999 s + period time
-----------------------------------	------------------------------

Warm-up time.....	1 min.
Signal / noise ratio.....	Min. 60 dB
Accuracy.....	Better than 0.1% of selected range
Signal dynamics, output.....	16 bit
Effect of supply voltage change.....	< 0.005% of span / VDC
Temperature coefficient.....	< ±0.01% of span / °C
Linearity error.....	< 0.1% of span
S0 supply.....	15 VDC / 25 mA
Special supply (programmable).....	5...15 VDC / 30 mA (acc. to order)
EMC immunity influence.....	< ±0.5%

Input specifications

Common input specifications

Max. offset.....	90% of selec. max. value
Measurement range.....	0...20 kHz
Min. measurement range.....	0.001 Hz
Low cut-off frequency.....	0.001 Hz
Min. pulse length.....	25 µs
Input types.....	NAMUR acc. to DIN 19234
Input types.....	Tacho
Input types.....	NPN / PNP
Input types.....	TTL
Input types.....	S0 acc. to DIN 43864

Output specifications

Current output

Signal range.....	0...20 mA
Min. signal range.....	5 mA
Load (@ current output).....	≤ 600 Ω
Load stability.....	≤ 0.01% of span / 100 Ω

Common output specifications

Updating time.....	20 ms
--------------------	-------

Relay output

Max. switching frequency.....	20 Hz
Max. voltage.....	150 VRMS
Max. current.....	2 AAC
Max. AC power.....	300 VA
Max. load at 24 VDC.....	1 A

Voltage output through internal shunt.....	See manual for details
Max. current, NPN output.....	130 mA
Max. voltage, NPN output.....	28 VDC
Frequency output range.....	0...1000 Hz
Min. pulse length.....	500 µs
Max. pulse length.....	999 ms
Max. duty cycle.....	50%
Frequency generator: Pulse length f < 50 Hz.....	Min. 10 ms
Frequency generator: Pulse length f < 50 Hz.....	Max. 999 s
Pulse length f ≥ 50 Hz.....	50% duty cycle
*of span.....	= of the presently selected range

Observed authority requirements

EMC.....	2014/30/EU
LVD.....	2014/35/EU

Approvals

EAC.....	TR-CU 020/2011
----------	----------------