

Pulse isolator

9202B

- Interface for NAMUR sensors and switches
- Extended self-diagnostics and detection of cable fault
- 1 or 2 channels
- Can be supplied separately or installed on power rail, PR type 9400
- SIL 2-certified via Full Assessment



Advanced features

- Configuration and monitoring by way of detachable display front (PR 4501).
- Selection of direct or inverted function for each channel via PR 4501.
- Advanced monitoring of internal communication and stored data.
- Optional redundant supply via power rail and/ or separate supply.
- SIL 2 functionality is optional and must be activated in a menu point.

Application

- 9202B can be mounted in the safe area or in zone 2 / Cl. 1 div. 2 and receive signals from zone 0, 1, 2 and zone 20, 21, 22 including mining / Class I/II/III, Div. 1, Gr. A-G.
- Pulse isolator for transmission of signals to the safe area from NAMUR sensors and mechanical switches installed in the hazardous area.
- Monitoring of error events and cable breakage via the individual status relay and/or a collective electronic signal via the power rail.
- The 9202B has been designed, developed and certified for use in SIL 2 applications according to the requirements of IEC 61508.

Technical characteristics

- 1 green and 2 yellow/red front LEDs indicate operation status and malfunction.
- 2.6 kVAC galvanic isolation between input, output and supply.

Mounting

- The devices can be mounted vertically or horizontally without distance between neighbouring units.

Applications

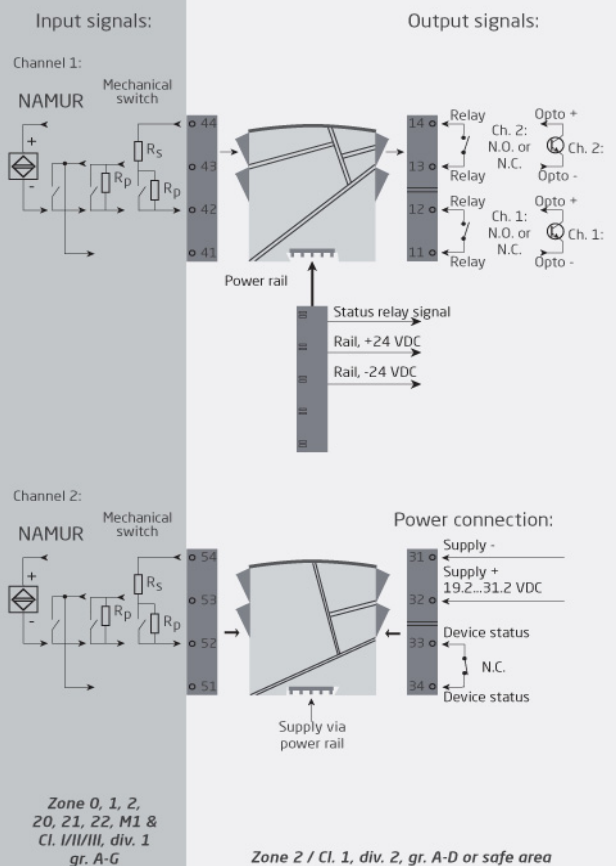

Order:

Type	Switch	Channels
9202B	Opto : 1	Single : A
	Relay N.O. : 2	Double : B
	Relay N.C. : 3	

Environmental Conditions

Operating temperature.....	-20°C to +60°C
Storage temperature.....	-20°C to +85°C
Calibration temperature.....	20...28°C
Relative humidity.....	< 95% RH (non-cond.)
Protection degree.....	IP20
Installation in.....	Pollution degree 2 & measurement / overvoltage cat. II

Mechanical specifications

Dimensions (HxWxD).....	109 x 23.5 x 104 mm
Dimensions (HxWxD) w/ 4501 / 4511.....	109 x 23.5 x 116 / 131 mm
Weight approx.....	170 g
Weight incl. 4501 / 4511 (approx.).....	185 g / 270 g
DIN rail type.....	DIN EN 60715/35 mm
Wire size.....	0.13...2.08 mm ² AWG 26...14 stranded wire
Screw terminal torque.....	0.5 Nm
Vibration.....	IEC 60068-2-6
2...13.2 Hz.....	±1 mm
13.2...100 Hz.....	±0.7 g

Common specifications**Supply**

Supply voltage.....	19.2...31.2 VDC
Fuse.....	400 mA SB / 250 VAC
Max. required power.....	≤ 3 W (2 channels)

Isolation voltage

Test /working: Input to any.....	2.6 kVAC / 300 VAC reinforced isolation
Analog output to supply.....	2.6 kVAC / 300 VAC reinforced isolation
Output 1 to output 2.....	1.5 kVAC / 150 VAC reinforced isolation
Status relay to supply.....	1.5 kVAC / 150 VAC reinforced isolation

Auxiliary supplies

NAMUR supply.....	8 VDC / 8 mA
Programming.....	Communication enabler 4511 / Programming front 4501
Response time for cable fault.....	< 200 ms

Input specifications

Sensor types.....	NAMUR according to EN 60947-5-6 / mechanical contact
Frequency range.....	0...5 kHz
Min. pulse length.....	> 0.1 ms
Input resistance.....	Nom. 1 kΩ
Trig level, signal.....	< 1.2 mA, > 2.1 mA
Trig level, cable fault.....	< 0.1 mA, > 6.5 mA

Output specifications**Relay output**

Max. switching frequency.....	20 Hz
Max. voltage.....	250 VAC / 30 VDC
Max. current.....	2 AAC / 2 ADC
Max. AC power.....	500 VA / 60 W

Status relay

Max. voltage.....	110 VDC / 125 VAC
Max. current.....	0.3 ADC / 0.5 AAC
Max. AC power.....	62.5 VA / 32 W

NPN outputs

Max. switching frequency.....	5 kHz
Min. pulse length.....	> 0.1 ms
Max. load, current / voltage.....	80 mA / 30 VDC
Voltage drop at 80 mA.....	< 2.5 VDC

Observed authority requirements

EMC.....	2014/30/EU
LVD.....	2014/35/EU

Approvals

ATEX 2014/34/EU.....	KEMA 07ATEX0146 X
IECEx.....	KEM 06.0039X
FM.....	3034430-C
INMETRO.....	NCC 12.1307 X
UL.....	UL 61010-1
EAC.....	TR-CU 020/2011
EAC Ex TR-CU 012/2011.....	RU C-DK.GB08.V.00410
CCOE.....	P337349/5
DNV-GL Marine.....	Stand. f. Certific. No. 2.4
SIL.....	SIL 2 certified & fully assessed acc. to IEC 61508