

- Holding, clamping and braking of round material
- Wide choice of variants
- Any assembly position

Clamping cartridges/units

Key features

FESTO

At a glance

- The clamping cartridges/units use spring force to hold round material in any required position.
- Able to stop and hold material for long periods, even in applications involving varying loads, fluctuating operating pressure and system leaks.
- The clamping force is released by pressurising the clamping cartridge.
- The clamping cartridges/units can be mounted in any position.
- Clamping cartridges/units are not suitable for positioning.
- The clamping cartridge KP and the clamping units KPE, KEC, KEC-S are standalone components.
- Cylinder with integrated clamping unit
 - ADN-KP
 - DSNU-...-KP
 - DSBC-...-C
 - DNCKE/DNCKE-S
- Backlash-free in clamped condition with varying loads on the piston rod:
 - Clamping cartridge/unit KP/KPE: No
 - Clamping unit KEC/KEC-S: Yes

Selection aid

Clamping cartridge KP → 4



- For in-house assembly of clamping units
- Not certified for use in safety-relevant control systems

Clamping unit KPE → 6



- Ready-to-install combination of clamping cartridge KP and housing
- Versatile mounting options → 7
- Not certified for use in safety-relevant control systems

Clamping unit KEC → 8



- **For use as holding device (static application):**
 - Holding and clamping in the event of a power failure
 - Protection against pressure failure and pressure drop
 - Securing the piston rod during intermediate stops for process operations
- Mounting hole pattern to ISO 15552 (DIN ISO 6431)
- Not certified for use in safety-relevant control systems

Clamping-unit cylinder KEC-...-S, for safety-related applications → 10



- **Pneumatic braking/holding device for use in safety-related parts of control systems.**
The clamping unit is not a complete safety solution. It can be used as part of a solution.
- Certified by the Institute for Occupational Safety and Health of the German Social Accident Insurance. Testing and Certification Bodies in DGUV Test. Pneumatic braking/holding device with safety function.
- **Use as a holding device (static application):**
 - Holding and clamping in the event of power failure
 - Protection against pressure failure and pressure drop
 - Holding the piston rod during intermediate stops, for operative procedures in a process
- **For use as a braking device (dynamic application):**
 - Braking or stopping a movement
 - Interrupting a movement if a danger area is entered
- Mounting hole pattern to ISO 15552 (DIN ISO 6431)
- When used as a braking device, the overtravel must be checked regularly
- Suitable for use in safety-related parts of control systems belonging to category 1 to EN ISO 13849-1 (reliable component). Additional control measures are required for use in higher categories.
- Products intended for use in safety-related applications must be selected, sized and arranged in accordance with the valid standards and regulations.

Clamping cartridges/units

Key features and type codes

Requirements for the round material to be clamped

in combination with clamping cartridge KP or clamping unit KPE

- Material:
 - Hard-chromium plated steel
 - Hardened steel
 - Rolled steel: tensile strength > 650 N/mm², hardness (HB30) > 175
- Diameter tolerance: h8
- Surface roughness: R_{max.} = 4 μm
- The specified holding forces refer to a static load. If these values are exceeded, slippage may occur
- Clamping cartridge KP and clamping unit KPE are not suitable for dynamic operation

in combination with clamping unit KEC

- Material:
 - Hard-chromium plated steel: coating thickness min. 20 μm
 - Hardened steel: min. HRC 60
- Diameter tolerance: h7 ... f7
- Surface roughness: R_{max.} = 4 μm
- The specified holding forces refer to a static load. If these values are exceeded, slippage may occur
- Clamping unit KEC is not suitable for dynamic operation
- The following applies to clamping unit KEC-S: Dynamic forces occurring during operation must not exceed the static holding force

Type codes

		KP	–	4	–	80	–	
Type								
KP	Clamping cartridge							
KPE	Clamping unit							
KEC								
Round material to be clamped ∅ [mm]								
Static holding force [N]								
Certification								
S	Certified by the Institute for Occupational Safety and Health of the German Social Accident Insurance. Testing and Certification Bodies in DGUV Test. Pneumatic braking/holding device with safety function.							

Clamping cartridges KP

Technical data

FESTO

Function

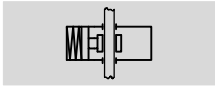

- \varnothing - Diameter of round material to be clamped:
4 ... 32 mm

-  - Force
80 ... 7500 N



-  - Note

Additional measures are required for use in safety-related control systems; in Europe, for example, the standards listed under the EC Machinery Directive must be observed. Without

additional measures in accordance with statutory minimum requirements, the product is not suitable for use in safety-related sections of control systems.

General technical data											
For round material \varnothing	4	6	8	10	12	16	20	25	32		
Pneumatic connection	M5					G1/8					
Design	Tilting wedge mechanism										
Type of mounting	Via self-configured housing										
Clamping type with effective direction	At both ends Clamping via spring force, air to release										
Static holding force [N]	80	180	350	350	600	1000	1400	2000	5000	7500	
Axial play under load [mm]	0.2	0.3	0.5		0.8			1.8			
Min. release pressure [bar]	3										
Assembly position	Any										
Product weight [g]	10	15	50	50	50	90	170	170	700	1600	

Operating and environmental conditions	
Operating medium	Compressed air in accordance with ISO 8573-1:2010 [7:4:4]
Note on operating/pilot medium	Operation with lubricated medium possible (in which case lubricated operation will always be required)
Operating pressure [bar]	≤ 10
Ambient temperature [°C]	-10 ... +80
Corrosion resistance class CRC ¹⁾	2

1) Corrosion resistance class CRC 2 to Festo standard FN 940070
Moderate corrosion stress. Indoor applications in which condensation may occur. External visible parts with primarily decorative requirements for the surface and which are in direct contact with the ambient atmosphere typical for industrial applications.

Materials

Sectional view

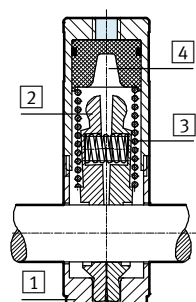

Clamping cartridge		
1	Body	Anodised aluminium
2	Clamping plates	Brass
3	Spring	Spring steel
4	Piston	POM
-	Seals	NBR, TPE-U(PU)

Clamping cartridges KP

Technical data

FESTO

Dimensions and ordering data

Download CAD data → www.festo.com

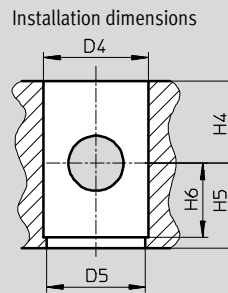
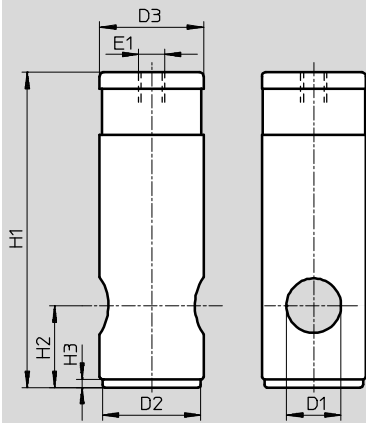

-  - Note

When installing the clamping cartridge in a housing, plain bearings must be installed on both sides of this housing.

For Ø	D1	D2	D3	D4	D5	E1	H1	H2
[mm]	Ø	Ø h12	Ø f9	Ø D9	Ø			
4	4	10	12	12	11	M5	28	7
6	6	14	16	16	15	M5	35	10
8	8	18	20	20	19	M5	62	17.5
10	10	18	20	20	19	M5	62	17.5
12	12	18	20	20	19	M5	62	17.5
16	16	22	24	24	23	G $\frac{1}{8}$	83	22
20	20	28	30	30	29	G $\frac{1}{8}$	100	25
	20	36	38	38	37	G $\frac{1}{8}$	115.5	30
25	25	46	48	48	47	G $\frac{1}{8}$	155	36
32	32	63	65	65	64	G $\frac{1}{8}$	195	55

For Ø	H3	H4	H5	H6	Weight	Part No.	Type
[mm]		min.	min.		[g]		
4	2	9	7	6	10	178452	KP-4-80
6	3	10	11	8	15	178453	KP-6-180
8	3	18	18.5	15.5	50	178454	KP-8-350
10	3	18	18.5	15.5	50	178455	KP-10-350
12	3	18	18.5	15.5	50	178456	KP-12-600
16	3	22	23	20	90	178457	KP-16-1000
20	3	25	26	23	170	178458	KP-20-1400
	3	30	31	28	170	178459	KP-20-2000
25	3	36	37	34	700	178460	KP-25-5000
32	3	55	56	53	1600	178461	KP-32-7500

Clamping units KPE

Technical data

FESTO

Function

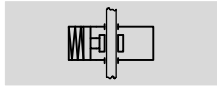

 www.festo.com

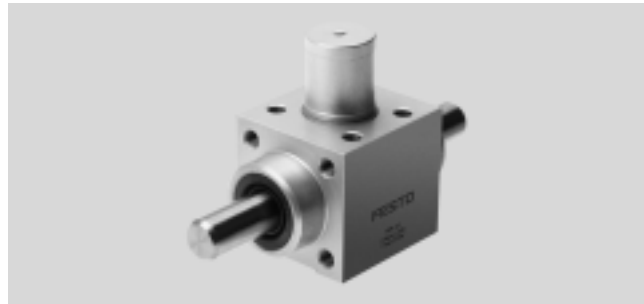

- \varnothing - Diameter of round material to be clamped:
4 ... 32 mm

-  - Force
80 ... 7500 N

-  - Note

Additional measures are required for use in safety-related control systems; in Europe, for example, the standards listed under the EC Machinery Directive must be observed. Without

additional measures in accordance with statutory minimum requirements, the product is not suitable for use in safety-related sections of control systems.

General technical data										
For round material \varnothing	4	6	8	10	12	16	20	25	32	
Pneumatic connection	M5					G1/8				
Design	Tilting wedge mechanism									
Type of mounting	Via mounting thread Via through-holes									
Clamping type with effective direction	At both ends Clamping via spring force, air to release									
Static holding force [N]	80	180	350	350	600	1000	2000	5000	7500	
Axial play under load [mm]	0.2	0.3	0.5				0.8		1.8	
Min. release pressure [bar]	3									
Assembly position	Any									
Product weight [g]	100	150	240	260	270	410	930	2000	4600	

Operating and environmental conditions	
Operating medium	Compressed air in accordance with ISO 8573-1:2010 [7:4:4]
Note on operating/pilot medium	Operation with lubricated medium possible (in which case lubricated operation will always be required)
Operating pressure [bar]	≤ 10
Ambient temperature [°C]	-10 ... +80
Corrosion resistance class CRC ¹⁾	2

1) Corrosion resistance class CRC 2 to Festo standard FN 940070
Moderate corrosion stress. Indoor applications in which condensation may occur. External visible parts with primarily decorative requirements for the surface and which are in direct contact with the ambient atmosphere typical for industrial applications.

Materials

Sectional view

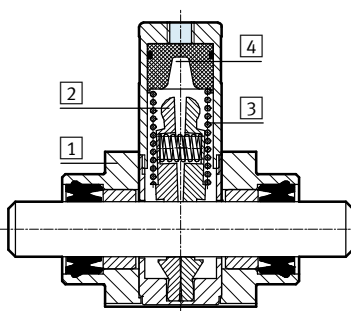

Clamping unit		
1	Housing	Anodised aluminium
2	Clamping plates	Brass
3	Spring	Spring steel
4	Piston	POM
-	Seals	NBR, TPE-U(PU)

Clamping units KPE

Technical data

FESTO

Mounting options

Via mounting thread

Via through-holes

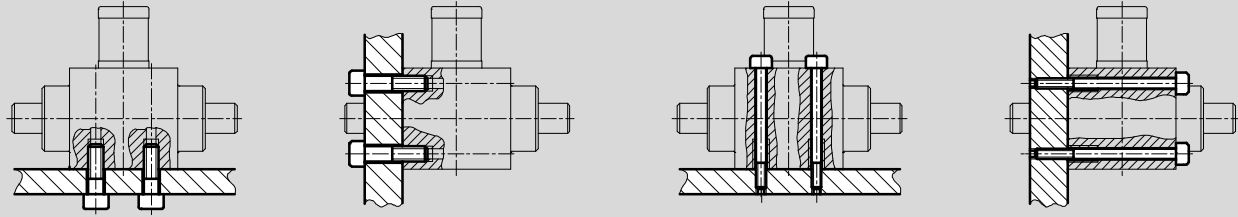

Dimensions and ordering data

For round material \varnothing 4 ... 6 mm

For round material \varnothing 8 ... 32 mm

Download CAD data → www.festo.com

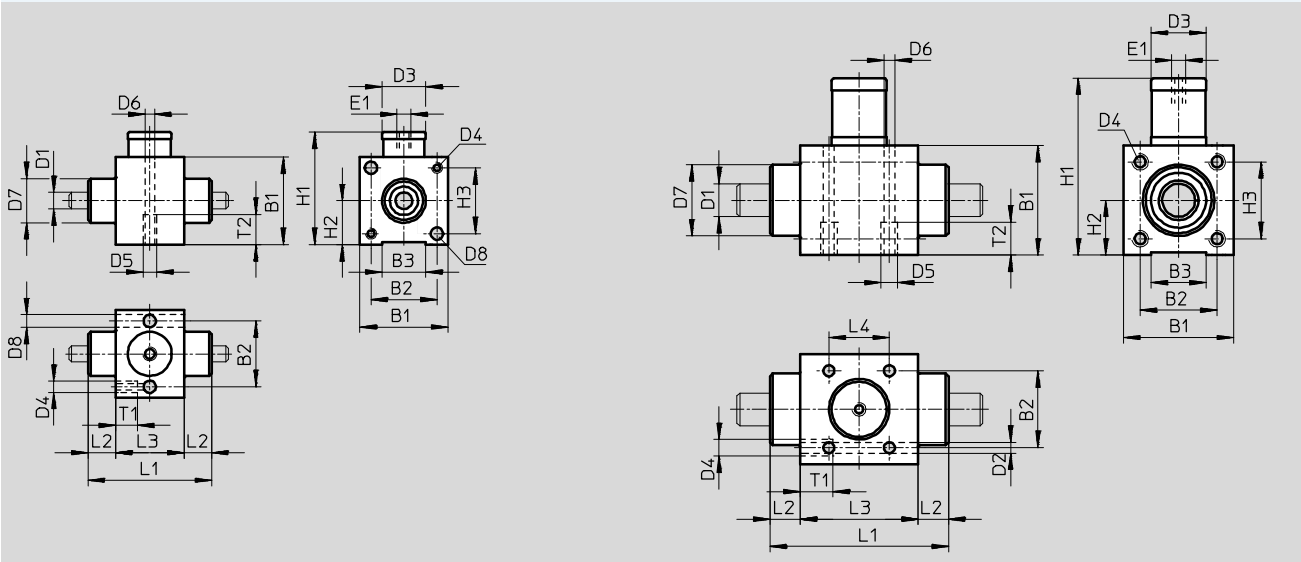

For \varnothing	B1	B2	B3	D1 \varnothing	D2 \varnothing	D3 \varnothing	D4	D5	D6 \varnothing	D7 \varnothing	D8 \varnothing	E1	H1	H2
4	27	19.5	12	4	-	12	-	M5	4.2	12	4.5	M5	34.5	13.5
6	32	24	16	6	-	16	-	M5	4.2	16	4.5	M5	41	16
8	36	27	20	8	4.2	20	M5	M5	4.2	22	-	M5	62.5	18
10	36	27	20	10	4.2	20	M5	M5	4.2	22	-	M5	62.5	18
12	40	28	20	12	5.2	20	M6	M6	5.2	28	-	M5	64.5	20
16	45	32.5	25	16	5.2	24	M6	M6	5.2	32	-	G $\frac{1}{8}$	83.5	22.5
20	65	50	38	20	6.5	38	M8	M8	6.5	45	-	G $\frac{1}{8}$	118	32.5
25	88	65	50	25	8.5	48	M10	M10	8.5	55	-	G $\frac{1}{8}$	163	44
32	118	90	70	32	10.3	65	M12	M12	10.3	60	-	G $\frac{1}{8}$	199	59

For \varnothing	H3	L1	L2	L3	L4	T1	T2	Weight	Part No.	Type
								[g]		
4	19.5	33	7.5	18	-	9	11	100	178462	KPE-4
6	24	45	10	25	-	9	11	150	178463	KPE-6
8	27	58	10	38	20	10	11	240	178464	KPE-8
10	27	62	12	38	20	10	11	260	178465	KPE-10
12	28	65	11	43	22	12	12	270	178466	KPE-12
16	32.5	69	12.5	44	22	12	12	410	178467	KPE-16
20	50	83	12.5	58	30	16	16	930	178468	KPE-20
25	65	100	15	70	34	20	20	2000	178469	KPE-25
32	90	154	25	104	60	24	24	4600	178470	KPE-32

Clamping units KEC

Technical data

FESTO

Function

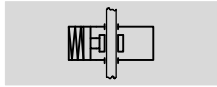

- \varnothing - Diameter of round material to be clamped:
16 ... 25 mm

- - Force
1300 ... 8000 N

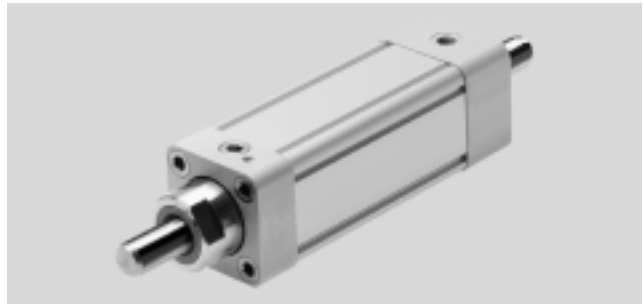

- - Note

Additional measures are required for use in safety-related control systems; in Europe, for example, the standards listed under the EC Machinery Directive must be observed. Without

additional measures in accordance with statutory minimum requirements, the product is not suitable for use in safety-related sections of control systems.

General technical data			
For round material \varnothing	16	20	25
Pneumatic connection	G $\frac{1}{8}$	G $\frac{1}{4}$	G $\frac{3}{8}$
Type of mounting	With female thread Via accessories → 12		
Clamping type with effective direction	At both ends Clamping via spring force, air to release		
Static holding force	1300	3200	8000
Min. release pressure [bar]	3.8		
Assembly position	Any		
Product weight [g]	1860	4515	16760

Operating and environmental conditions	
Operating medium	Compressed air in accordance with ISO 8573-1:2010 [7:4:4]
Note on operating/pilot medium	Operation with lubricated medium possible (in which case lubricated operation will always be required)
Operating pressure [bar]	3.8 ... 10
Ambient temperature [°C]	-20 ... +80
ATEX	Specified types → www.festo.com

- - Note

The specified holding force refers to a static load. If this value is exceeded, slippage may occur. Dynamic forces occurring during operation must not exceed the static holding force if

slippage is to be avoided. The clamping unit is backlash-free in the clamped condition when varying loads are applied to the piston rod. Lateral loads and bending moments

on the round material can impair the function. (Make sure that the load on the round material is only in the direction of movement.)

Actuation:

The clamping unit may only be released when the forces on the piston have reached an equilibrium. Otherwise the sudden movement of the piston rod could cause an accident. Blocking off the air supply at both ends (e.g. with a 5/3-way valve) does not provide any safety.

Clamping units KEC

Technical data

FESTO

Materials

Sectional view

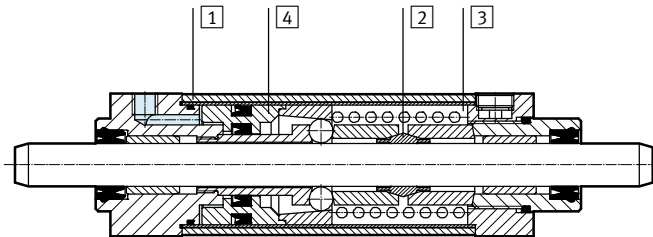

Clamping unit		
1	Housing	Wrought aluminium alloy
2	Clamping jaws	Tool steel
3	Spring	High-alloy steel
4	Piston	Wrought aluminium alloy
-	Seals	NBR, TPE-U(PU)

Dimensions and ordering data

Download CAD data → www.festo.com

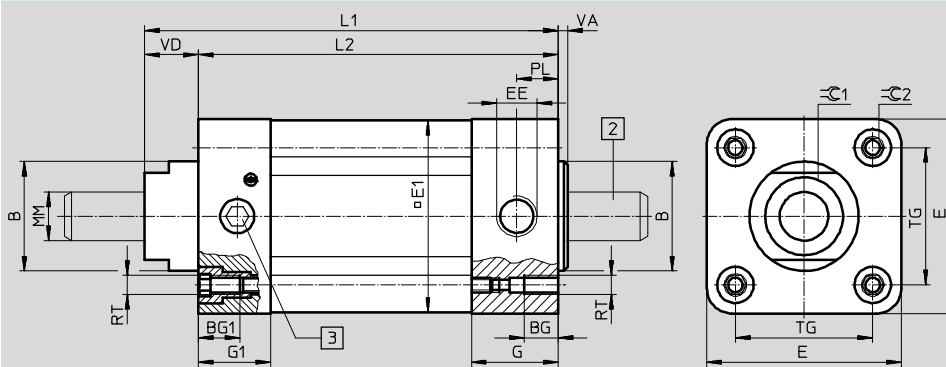

- Note

The clamping unit can only be exhausted when it contains round material.

- 2 Round material to be clamped
- 3 Locking screw

For \varnothing	B	BG	BG1	E	E1	EE	G	G1	L1	L2	MM
[mm]	\varnothing f8										\varnothing
16	35	15	15	54	53	G $\frac{1}{8}$	27	22	178	160	16
20	45	14	17	80	79	G $\frac{1}{4}$	30	29.5	208.5	187	20
25	55	17	17	126	126	G $\frac{3}{8}$	32.5	32.5	287	258	25

For \varnothing	PL	RT	TG	VA	VD	$\text{C}1$	$\text{C}2$	Weight	Part No.	Type
[mm]								[g]		
16	13	M6	38	5.5	18	30	6	1860	527492	KEC-16
20	15.5	M8	56.5	6	21.5	36	8	4515	527493	KEC-20
25	17	M10	89	7	29	41	10	15600	527494	KEC-25

Clamping units KEC-...-S

Technical data

FESTO

Function

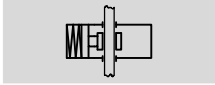

- \varnothing - Diameter of round material to be clamped:
16 ... 25 mm

- - Force
1300 ... 8000 N



General technical data			
For round material \varnothing	16	20	25
Pneumatic connection	G $\frac{1}{8}$	G $\frac{1}{4}$	G $\frac{3}{8}$
Type of mounting	With female thread Via accessories → 12		
Clamping type with effective direction	At both ends Clamping via spring force, air to release		
Static holding force	1300	3200	8000
Min. release pressure [bar]	3.8		
Assembly position	Any		
Function	Single-channel to EN ISO 13849-1, category 1		
Safety function	Holding and stopping a movement		
Certification	Certified by the Institute for Occupational Safety and Health of the German Social Accident Insurance. Testing and Certification Bodies in DGUV Test		
Product weight [g]	1860	4515	15600

Operating and environmental conditions	
Operating medium	Compressed air in accordance with ISO 8573-1:2010 [7:4:4]
Note on operating/pilot medium	Operation with lubricated medium possible (in which case lubricated operation will always be required)
Operating pressure [bar]	3.8 ... 8
Max. permissible test pressure [bar]	10
Ambient temperature [°C]	-10 ... +60

- - Note

The specified holding force refers to a static load. If this value is exceeded, slippage may occur. Dynamic forces occurring during operation must not exceed the static holding force if slippage is to be avoided. The clamping unit is backlash-free in the clamped condition when varying loads are applied to the piston rod. Lateral loads and bending moments on the round material can impair the function. (Make sure that the load on the round material is only in the direction of movement.)

Actuation:
The clamping unit may only be released when the forces on the piston have reached an equilibrium. Otherwise the sudden movement of the piston rod could cause an accident. Blocking off the air supply at both ends (e.g. with a 5/3-way valve) does not provide any safety.

Materials

Sectional view

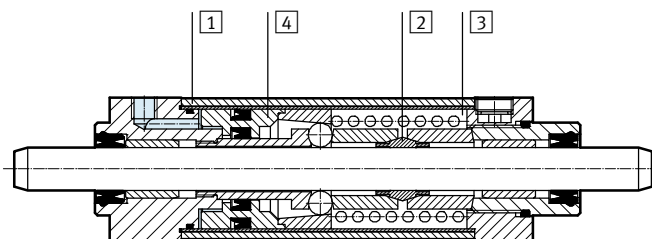

Clamping unit		
1	Housing	Wrought aluminium alloy
2	Clamping jaws	Tool steel
3	Spring	High-alloy steel
4	Piston	Wrought aluminium alloy
-	Seals	NBR, TPE-U(PU)

Clamping units KEC-...-S

Technical data

FESTO

Dimensions and ordering data

for use in safety-relevant control systems

Download CAD data → www.festo.com

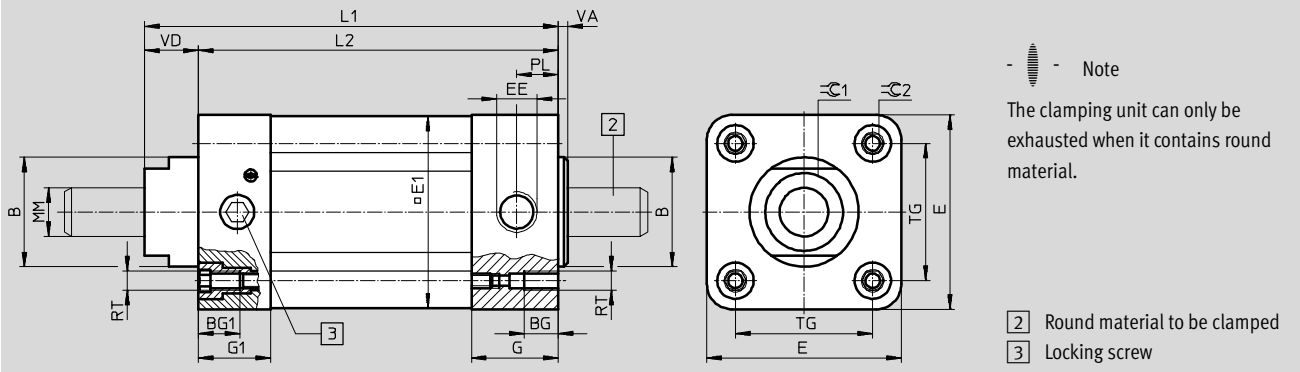

For \varnothing [mm]	B \varnothing	BG	BG1	E	E1	EE	G	G1	L1	L2	MM \varnothing
16	35	15	15	54	53	G $\frac{1}{8}$	27	22	178	160	16
20	45	14	17	80	79	G $\frac{1}{4}$	30	29.5	208.5	187	20
25	55	17	17	126	126	G $\frac{3}{8}$	32.5	32.5	287	258	25

For \varnothing [mm]	PL	RT	TG	VA	VD	\varnothing C1	\varnothing C2	Weight [g]	Part No.	Type
16	13	M6	38	5.5	18	30	6	1860	538242	KEC-16-S
20	15.5	M8	56.5	6	21.5	36	8	4515	538243	KEC-20-S
25	17	M10	89	7	29	41	10	15600	538244	KEC-25-S

Note

The overtravel is the distance that the piston rod covers between exhausting of the clamping unit and coming to a standstill. It must be determined by the customer when the machine is set up.

When the clamping unit is used as a braking device, an increase in the overtravel as a function of the load and the frequency of braking (wear)

must be expected. The clamping unit KEC-S can be used in safety-related parts of control systems belonging to category 1 (reliable component) as defined by EN ISO 13849-1. For use in higher categories than category 1 to EN ISO 13849-1, the overtravel must be achieved even in the event of faults. It is dependent

on the environmental conditions and stress, e.g.:

- Operating pressure
- Nominal size of switching valve
- Cable length
- Diameter of the connecting cable to the clamping unit
- Load and speed

The overtravel can be reduced by attaching a quick exhaust valve to the supply port of the clamping unit.

Clamping units

Accessories



Foot mounting HNC

Material:
Galvanised steel
Free of copper and PTFE

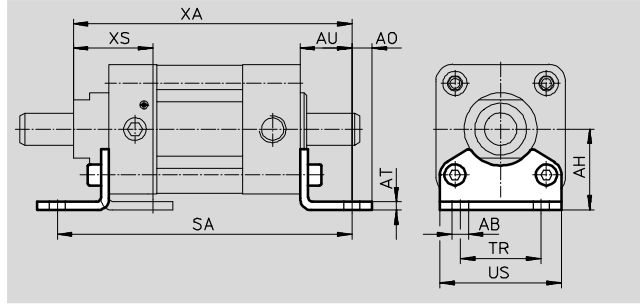

Dimensions and ordering data														
For \varnothing	AB	AH	AO	AT	AU	SA	TR	US	XA	XS	CRC ¹⁾	Weight	Part No.	Type
[mm]	\varnothing											[g]		
16	10	36	9	5	28	216	36	54	206	42	2	193	174370	HNC-40
20	10	50	12.5	6	32	251	50	75	240.5	48.5	2	436	174372	HNC-63
25	14.5	71	17.5	6	41	340	75	110	328	64	2	1009	174374	HNC-100

1) Corrosion resistance class CRC 2 to Festo standard FN 940070
Moderate corrosion stress. Indoor applications in which condensation may occur. External visible parts with primarily decorative requirements for the surface and which are in direct contact with the ambient atmosphere typical for industrial applications.

Flange mounting FNC

Material:
Galvanised steel
Free of copper and PTFE

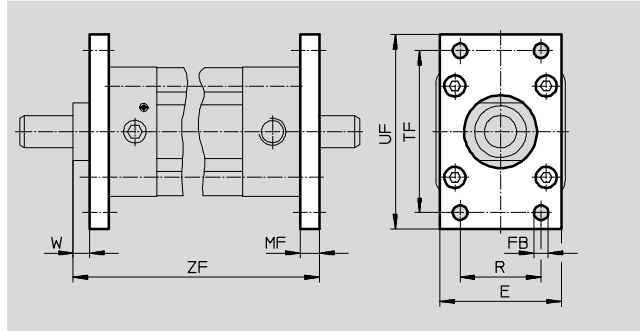

Dimensions and ordering data													
For \varnothing	E	FB	MF	R	TF	UF	W	ZF	CRC ¹⁾	Weight	Part No.	Type	
[mm]		\varnothing H13								[g]			
16	54	9	10	36	72	90	8	188	1	291	174377	FNC-40	
20	75	9	12	50	100	120	9.5	220.5	1	679	174379	FNC-63	
25	110	14	16	75	150	175	13	303	1	2041	174381	FNC-100	

1) Corrosion resistance class CRC 1 to Festo standard FN 940070
Low corrosion stress. For dry indoor applications or transport and storage protection. Also applies to parts behind covers, in the non-visible interior area, and parts which are covered in the application (e.g. drive trunnions).