

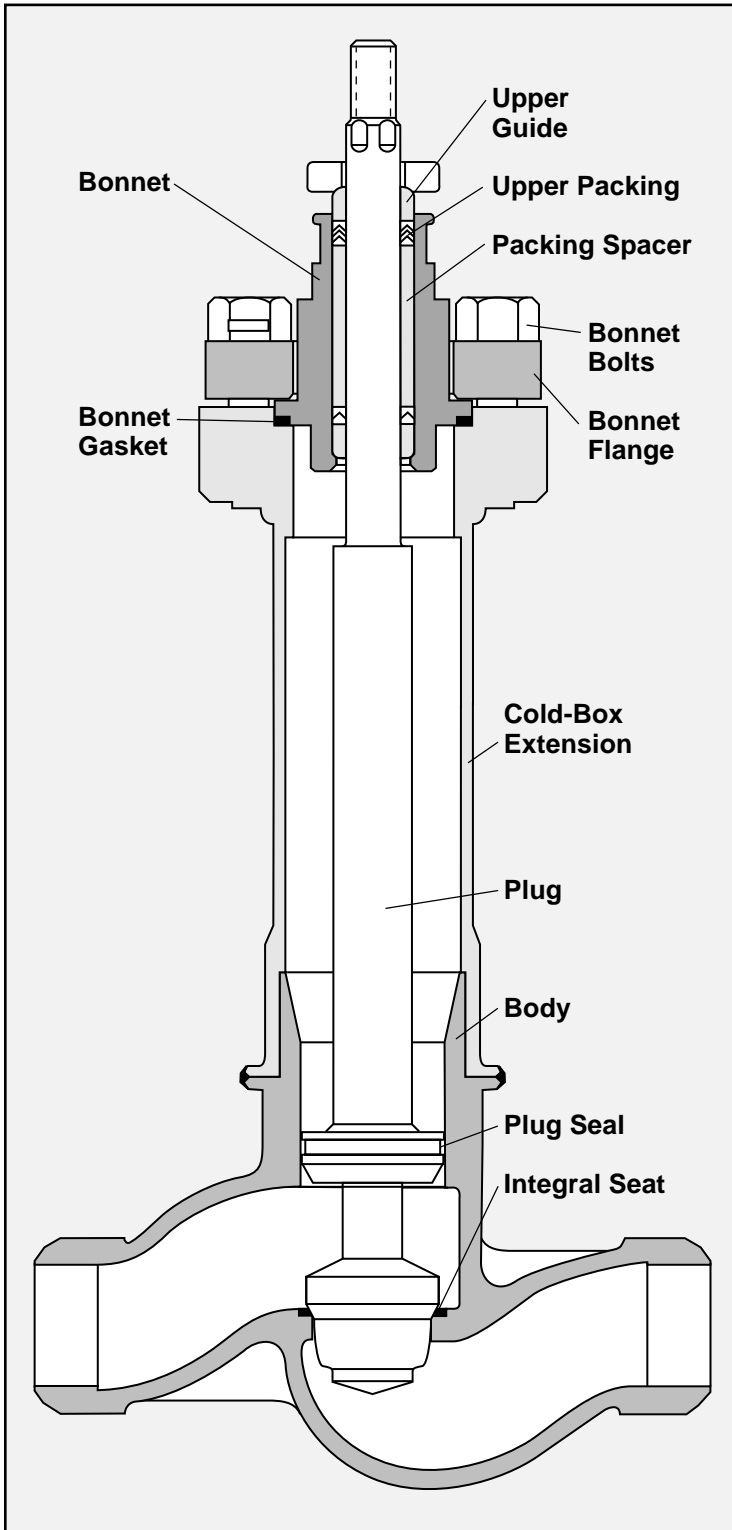

*Valtek Mark Six  
Control Valves*

## Valtek Mark Six Control Valves

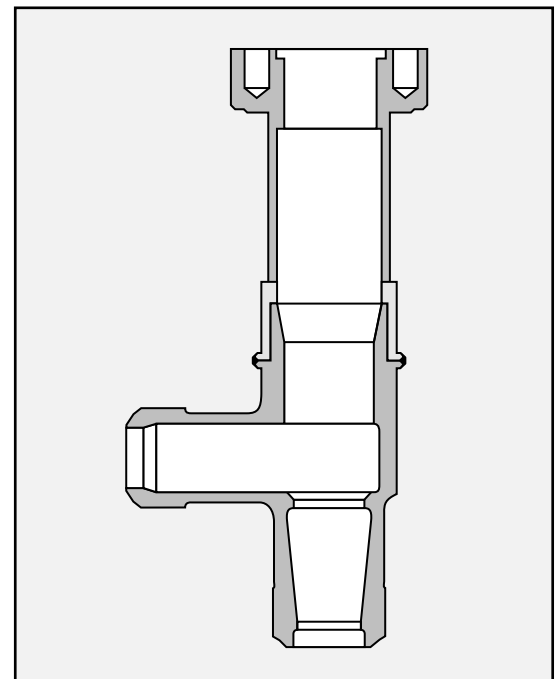

**Figure 1: Mark Six Design**

The Valtek® Mark Six™ is a globe-style, single-seat, top-entry automatic control valve with a fabricated extension for cold box cryogenic applications to  $-425^{\circ}\text{F}$  /  $-218^{\circ}\text{C}$ . Mark Six bodies are constructed of bronze or austenitic stainless steel for high-impact strength at low temperatures with minimum heat transfer. Mark Six is designed for high flow capacity with a minimum of mass to reduce boil-off on valve cool-down.

The Mark Six extension design permits easy access and removal of the valve trim without breaking down the cold box. During operation, a small amount of liquified gas passes into the extension bonnet area where it vaporizes and insulates the packing from the liquified gas temperature. The pressure resulting from the vaporization of the liquid prevents additional liquid from passing into the bonnet area.

The Mark Six is equipped with a standard, high-performance Valtek cylinder actuator, providing high thrust for tight shutoff and exceptionally accurate control.



**Figure 2: Angle Body Construction**

# Valtek Mark Six Features and Specifications

## Features Include:

- Streamlined, lightweight body for reduced heat transfer
- Simple bonnet seal for easy maintenance and low thermal losses
- Top-entry for easy service without breaking down cold box
- Cold box extension for packing protection and to prevent icing of the stem
- Single seat for precise throttling and tight shutoff
- Smooth, nearly constant area; internal flow passages for high capacity and minimum turbulence
- High-thrust Mark One cylinder actuator for high performance, exceptional control and tight shutoff
- Many interchangeable parts with other standard Valtek control products

**Table I: Body Specifications**

Sizes	1 through 8-inch
Forms	Globe, angle
ANSI ratings	150, 300, 600
End Connections	Buttweld — all sizes Socketweld — 1-inch Separable flange — 1 – 4-inch, class 150 / 600 6 – 8-inch, class 300 / 600 Integral flange — all sizes (optional)
Bonnet Type	Standard
Bonnet Flange	Separable
Packing Configurations	Standard Twin seal
Trim Characteristics	Equal percentage Linear Quick open
Hard Facings seat surface	No. 6 Stellite®; full contour
Soft Seat	TFE Teflon® FEP Teflon Kel-F®
Guides	Widely spaced stem
Gaskets	Flat, spiral wound



**Table II: Standard Materials of Construction**

Body	304, 316, 316L stainless steel, bronze
Bonnet	304, 316, 316L stainless steel, bronze
Bonnet flange	316 stainless steel
Bonnet gasket	Teflon, Kel-F
Plug	316 stainless steel, Monel®
Plug seal	Teflon
Spring-Energized	FEP Teflon / 316 stainless Seal steel
Guides	Bronze, glass-loaded Teflon, Stellite
Packing	Teflon, glass-filled Teflon
Packing spacer	316 stainless steel, bronze
Body bolts	Stainless steel
Gland flange	316 stainless steel
Gland flange nuts and bolts	Stainless steel
Yoke clamp	Precision cast stainless steel

## Valtek Mark Six Trim

### Plug Seals

The simple plug seal provides an effective vapor barrier between the liquified gas and packing. A small amount of liquified gas vaporizes when passing into the cold box extension. The pressure resulting from the vaporized liquid prevents additional liquid from entering the bonnet area.

On vented plugs, a small amount of liquid will vaporize when entering the bonnet area through a small vent hole in the plug head. In non-vented plugs, the spring-energized Teflon seal allows a small quantity of liquid into the bonnet area over a period of time. The pressure may require up to 24 hours to balance. In both cases, a Teflon sleeve guides the plug head in the polished bore of the valve body.

Since few parts are used in the seal, heat transfer to the fluid is reduced. Additionally, since the plug seal is bonded directly to the plug stem, effective sealing does not depend on the thermal contraction rates of different metals as in more complex sealing assemblies. An encapsulated bonnet gasket prevents leaks of process fluid to the atmosphere. A variety of trim combinations, including non-sparking, are available.

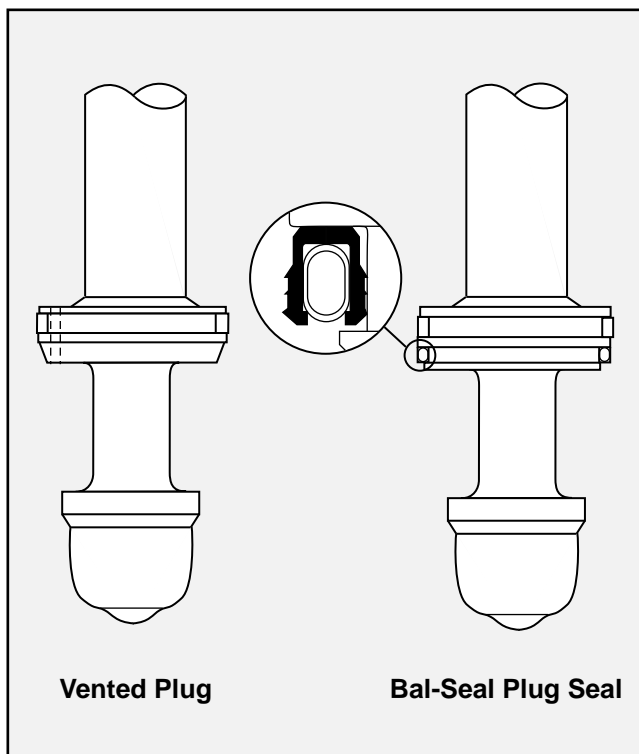

**Figure 3: Mark Six Plug Designs**

### Soft Plugs

Bubble-tight shutoff is achieved by adding Teflon or Kel-F onto the seating surface of the plug. Plug sizes up to 1½-inches use a threaded plug head design that clamps the elastomeric insert between the plug head and the plug stem. Plug sizes 2-inches and larger use a bolted design to retain the elastomeric insert. Self-locking inserts prevent the plug head from backing out of the plug stem and the bolts from backing out of the plug head. Leakage corresponding to this construction is Class VI or ANSI B16.104 - 1976, bubble-tight. Soft plug assemblies and standard plugs are interchangeable.

### Seats

Most Valtek Mark Six valves use an integral seat machined into the body. Flow capacity can typically be adjusted by changing the shape of the plug head. Valves with small capacities or renewable seats use screwed-in seat rings.

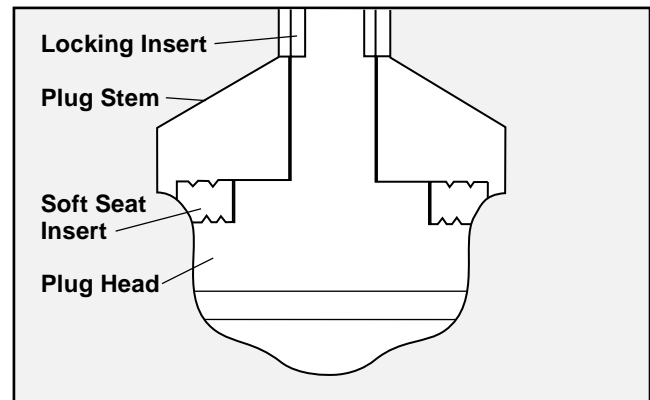

**Figure 4: Threaded Plug Head**

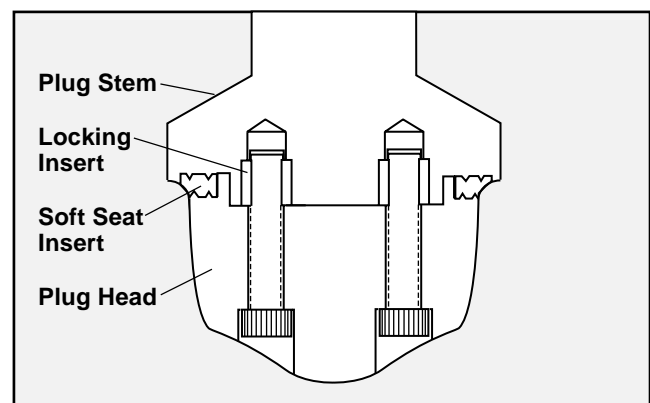
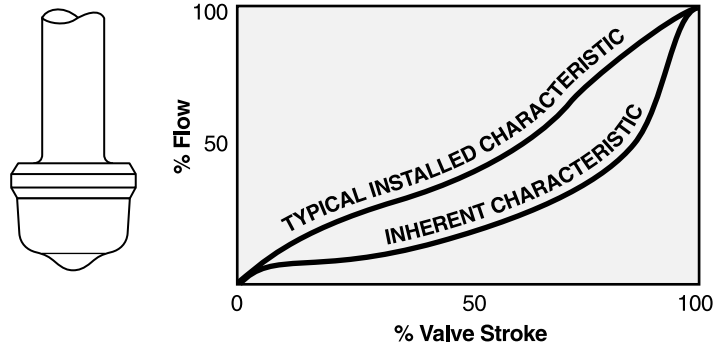

**Figure 5: Bolted Plug Head**

# Valtek Mark Six Flow Characteristics

## Equal Percentage

Equal percentage characteristic is commonly used in process control. The change in flow per unit of valve stroke is directly proportional to the flow occurring just before the change is made. While the flow characteristic of the valve may be equal percentage, most control loops produce an installed characteristic, which approaches linear when the overall system-pressure drop is large relative to that across the valve.



## Linear

Linear inherent characteristic produces equal changes in flow per unit of valve stroke regardless of plug position. Linear plugs are used on systems where the valve pressure drop is a major portion of the total system-pressure drop.

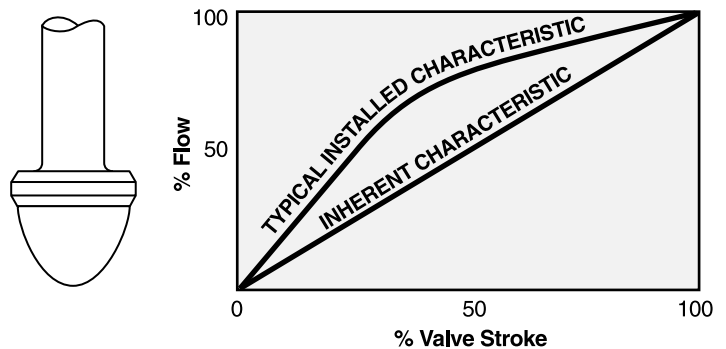

## Quick Open

Quick-open plugs are used for on-off service and are primarily designed to produce maximum flow quickly.

## Trim Types

Three trim types are available. Standard full-area trim provides maximum  $C_v$ . Reduced trim is available in a wide variety of sizes when lower  $C_v$  values and large bodies are required. Flow capacity is usually determined by the size of the plug head. Integral trim uses a seat machined into the body.

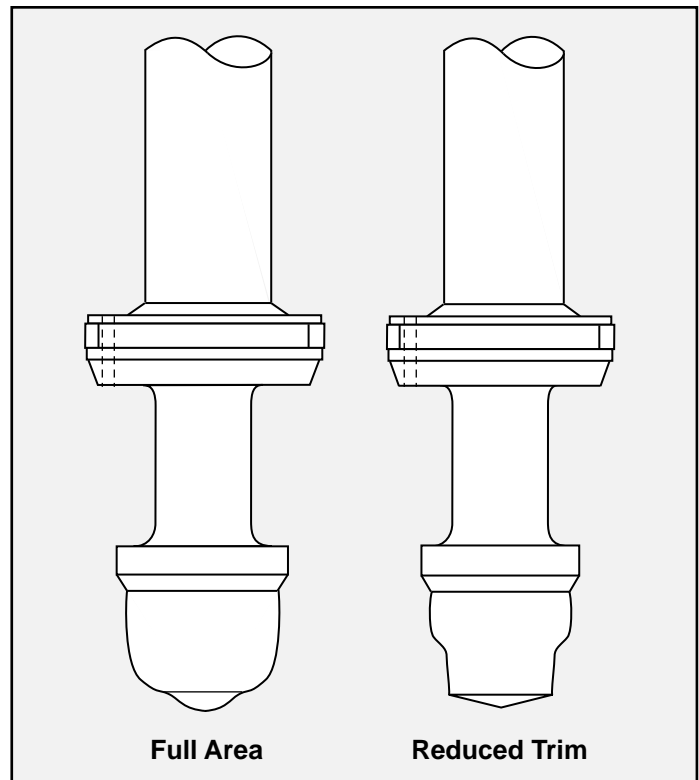

Figure 6: Plug Trims

## Valtek Mark Six Standard Body Construction

The streamlined Mark Six body with fabricated bonnet extension provides maximum flow capacity while minimizing thermal losses. Both the number and weight of body components are kept at a minimum, reducing heat transfer to the fluid. One-piece body construction without gasketed joints eliminates the possibility of leaks to the cold box.

Mark Six bodies are constructed of bronze or austenitic stainless steel, both of which are face-centered cubic metals that have high yield, tensile and impact strengths at cryogenic temperatures.

### Packing

Valve packing is readily accessible from outside the cold box, and the bonnet flange bolting is located near the surface of the cold box. Standard packing is Teflon V-rings. Glass-filled Teflon and square Grafoil® packing are optional.

### Guiding

The two guides used in the packing box are easily removed. The top guide also serves as the packing follower. Both guides are spaced widely apart, improving guiding. Glass-filled Teflon lined stainless steel or bronze guides completely eliminate guide /stem galling. Solid bronze or Stellite guides are available.

### Gaskets

The bonnet bottom is metal-to-metal in the body and fully retains the bonnet gasket. Bonnet gasket compression is determined by the depth of the gasket step on the bonnet which is machined to provide the compression required by the gasket. FEP and TFET Teflon or Kel-F flat gaskets are used.

## Aluminum Construction

The Valtek fabricated Mark Six valve, available in standard sizes of 1/2- through 8-inches with ANSI Class 150 / 600 rating, offers excellent control of fluids in cryogenic services to -325° F / -198° C. Fabricated from aluminum bar stock, the Mark Six body can be machined without foundry delays and can be tailor-made to meet customer requirements. One-piece body construction and the use of aluminum precludes the need for transition joints, thereby eliminating the possibility of leaks to the cold box.

### Body Configuration

The fabricated Mark Six body comes with aluminum butt-weld end connections and is rated for 150 / 600 ANSI Class applications. Sizes ranging from 1/2- to 2-inch are available in offset, angled body and in-line configurations. Larger sizes are available in offset and in-line standard configurations. The bonnet bolting is located away from the piping and is accessible at the surface of the cold box.

### Seals and Seats

The valve features a screwed-in seat design to allow for full-area or reduced  $C_v$  trim. A soft seat is optional for Class VI, bubble-tight shutoff at cryogenic temperatures, using Kel-F as a seat material. An encapsulated bonnet gasket prevents leaks of process fluid to the atmosphere. The packing is insulated from the process temperatures by vaporized process fluid in the bonnet extension, thereby preventing freezing. Packing is readily accessible from outside of the cold box.

### Actuator

The fabricated Mark Six valve is equipped with a standard Flowserve high-performance, high-thrust actuator, providing tight shutoff and exceptionally accurate control, as well as interchangeability with other standard Valtek control products.

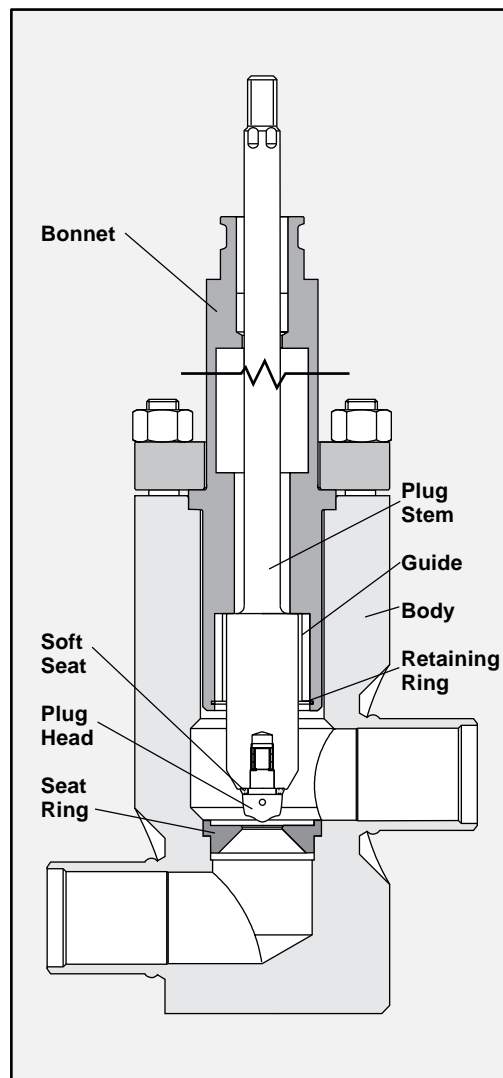

**Figure 7: Construction**

## Valtek Mark Six

### Trim Data, Shipping Weights, Extension Lengths

**Table III: Trim Data (inches / mm)**

Valve Size	Seat Diameter		Stem Diameter		Stroke		Approx. C <sub>v</sub>
	(inches)	(mm)	(inches)	(mm)	(inches)	(mm)	
1	0.125*	0.32	0.56	1.4	0.50	1.3	0.5
	1.00	2.5	0.56	1.4	0.75	1.9	1.5
	1.00	2.5	0.56	1.4	0.75	1.9	2.5
	1.00	2.5	0.56	1.4	0.75	1.9	4.0
	1.00	2.5	0.56	1.4	0.75	1.9	6.0
	1.00	2.5	0.56	1.4	0.75	1.9	9.0
	1.00	2.5	0.56	1.4	0.75	1.9	12.0
	1.00	2.5	0.56	1.4	0.75	1.9	15.5
1½	1.25	3.2	0.88	2.2	1.00	2.5	6.0
	1.25	3.2	0.88	2.2	1.00	2.5	15.0
	1.25	3.2	0.88	2.2	1.00	2.5	31.0
2	1.62	4.1	0.88	2.2	1.50	3.8	15.0
	1.62	4.1	0.88	2.2	1.50	3.8	30.0
	1.62	4.1	0.88	2.2	1.50	3.8	56.0
3	2.62	6.7	1.12	2.8	2.00	5.1	30.0
	2.62	6.7	1.12	2.8	2.00	5.1	60.0
	2.62	6.7	1.12	2.8	2.00	5.1	116.0
4	3.50	8.9	1.12	2.8	2.50	6.4	60.0
	3.50	8.9	1.12	2.8	2.50	6.4	120.0
	3.50	8.9	1.12	2.8	2.50	6.4	193.0
6	5.00	12.7	2.00	5.1	3.00	7.6	200.0
	5.00	12.7	2.00	5.1	3.00	7.6	453.0
8	6.25	15.9	2.00	5.1	4.00	10.2	300.0
	6.25	15.9	2.00	5.1	4.00	10.2	687.0
10	8.00	20.3	2.50	6.4	4.00	10.2	500.0
	8.00	20.3	2.50	6.4	4.00	10.2	1014.0

\*Available with screwed-in seat ring only

**Table IV: Bonnet Extension Lengths**

Body Size (inches)	Extension Lengths (inches)				
	12	15	18	24	30
1	12	15	18	24	
1½	12	15	18	24	30
2	12	15	18	24	30
3	18	21	24	30	36
4	18	21	24	30	36
6	24	27	30	36	
8	24	27	30	36	
10	30	33	36	42	

### Estimated Shipping Weights Globe with Cylinder Actuators and Positioners (lbs.)

Size (inches)	ANSI Class		
	150	300	600
1	70	70	70
1½	85	85	85
2	95	95	95
3	190	200	210
4	275	285	300
6	400	610	640
8	640	840	880
10	1110	1465	1660

### Add for Oversize Cylinder Actuators (lbs.)

Original Size	Oversize	Add
25	50	30
50	100	90
100	200	125

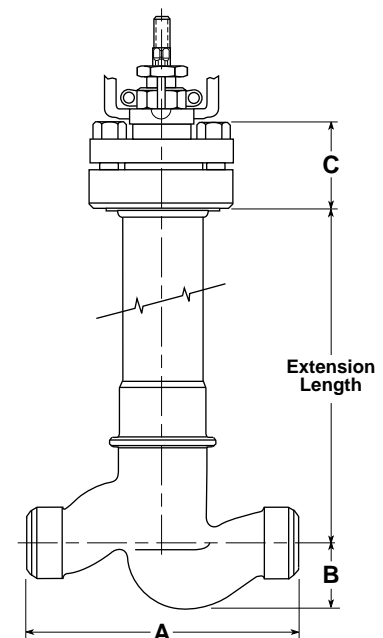

# Valtek Mark Six Dimensions

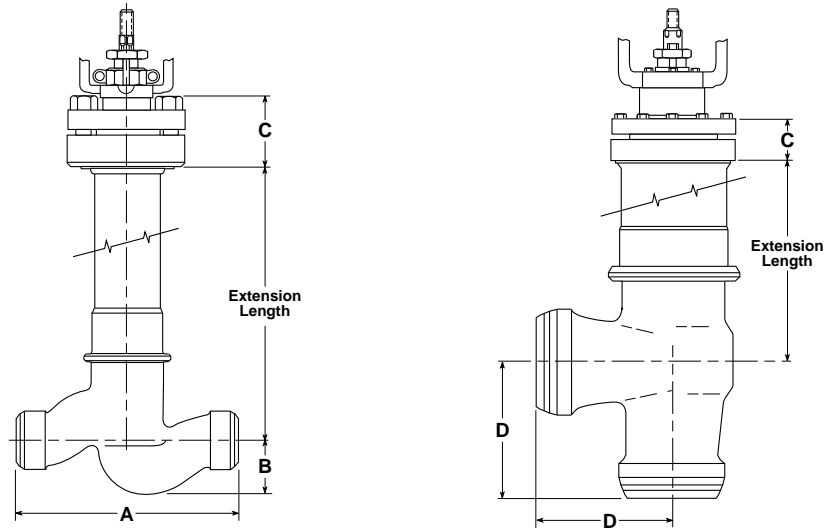

**Table V: Dimensions for Class 150, 300 and 600**

Body Size	ANSI / GLOBE Class 150 - 600		A						B		C		D				Clearance Above Actuator Required for Disassembly	
			ANSI / ISA										Class 150		Class 300 - 600			
	Class 150	Class 300	Class 600	Class 150	Class 300	Class 600	Class 150	Class 300 - 600	Class 150	Class 300 - 600	Class 150	Class 300 - 600	Class 150	Class 300 - 600				
1	8.50	216	7.25	184	7.75	197	8.25	210	1.75	44	3.80	96	4.25	108	4.25	108	6.8	172
1 1/2	9.50	241	8.75	222	9.25	235	9.88	251	2.31	58	3.93	100	4.75	121	4.75	121	8.9	226
2	11.50	291	10.00	254	10.50	267	11.25	286	2.25	57	4.06	103	5.75	146	5.75	146	9.1	231
3	14.00	356	11.75	298	12.50	318	13.25	337	3.39	86	5.34	136	7.00	178	7.00	178	11.3	287
4	17.00	432	13.88	353	14.50	368	15.50	394	5.22	133	6.06	154	8.75	222	8.75	222	14.1	359
6			17.75	451					5.48	139	6.04	153	8.88	225			16.1	409
6					18.62	473	20.00	508	5.75	146	6.19	208			11.00	279	18.2	462
8			21.38	543					7.08	179	6.94	176	13.00	333			20.0	508
8					22.38	568	24.00	610	7.48	190	8.75	222			13.00	333	21.8	554
10			26.50	673					8.44	214	7.37	187					21.4	544
10					27.88	708	29.62	752	8.93	227	7.37	187					21.4	544

Flowserve Corporation has established industry leadership in the design and manufacture of its products. When properly selected, this Flowserve product is designed to perform its intended function safely during its useful life. However, the purchaser or user of Flowserve products should be aware that Flowserve products might be used in numerous applications under a wide variety of industrial service conditions. Although Flowserve can (and often does) provide general guidelines, it cannot provide specific data and warnings for all possible applications. The purchaser/user must therefore assume the ultimate responsibility for the proper sizing and selection, installation, operation and maintenance of Flowserve products. The purchaser/user should read and understand the Installation Operation Maintenance (IOM) instructions included with the product, and train its employees and contractors in the safe use of Flowserve products in connection with the specific application.

While the information and specifications presented in this literature are believed to be accurate, they are supplied for informative purposes only and should not be considered certified or as a guarantee of satisfactory results by reliance thereon. Nothing contained herein is to be construed as a warranty or guarantee, express or implied, regarding any matter with respect to this product. Because Flowserve is continually improving and upgrading its product design, the specifications, dimensions and information contained herein are subject to change without notice. Should any question arise concerning these provisions, the purchaser/user should contact Flowserve Corporation at any of its worldwide operations or offices.

For more information, contact:

For more information about Flowserve, contact [www.flowserve.com](http://www.flowserve.com) or call USA 972 443 6500

**Regional Headquarters**

1350 N. Mt. Springs Prkwy.  
Springville, UT 84663  
Phone 801 489 8611  
Facsimile 801 489 3719

12, av. du Québec, B.P. 645  
91965, Courtaboeuf Cedex,  
France  
Phone (33 1) 60 92 32 51  
Facsimile (33 1) 60 92 32 99

104 Chelsea Parkway  
Boothwyn, PA 19061 USA  
Phone 610 497 8600  
Facsimile 610 497 6680

12 Tuas Avenue 20  
Republic of Singapore 638824  
Phone (65) 862 3332  
Facsimile (65) 862 4940

**Quick Response Centers**

5114 Railroad Street  
Deer Park, TX 77536 USA  
Phone 281 479 9500  
Facsimile 281 479 8511

1300 Parkway View Drive  
Pittsburgh, PA 15205 USA  
Phone 412 787 8803  
Facsimile 412 787 1944

Flowserve and Valtek are registered trademarks of Flowserve Corporation.

